

THREE POINTS INTERNAL MICROMETER



3227- 4



3227- 8



3227- 16



3227- 125

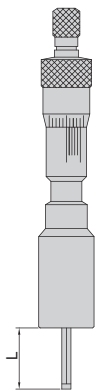

Type A
3-6mm, carbide points
two points

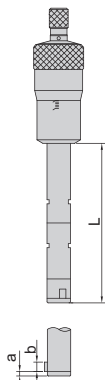

Type B
6-12mm, steel points
three points

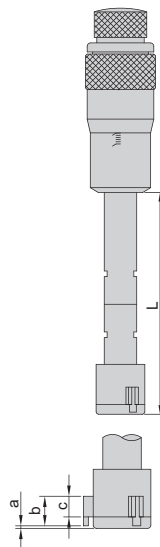

Type C
12-100mm, carbide points
three points

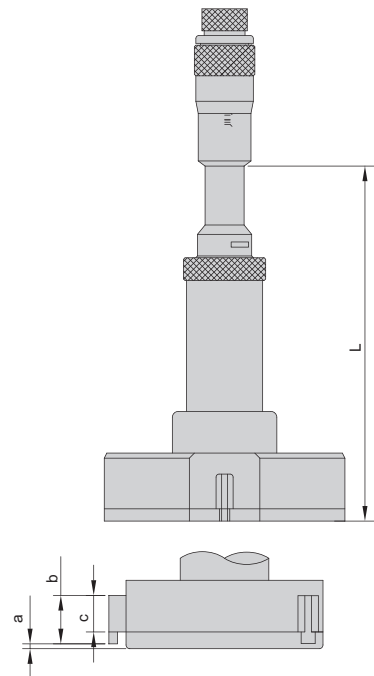

Type D
100-300mm, carbide points
three points

setting ring



3-100mm: included
100-300mm: optional

extension rod



3-6mm: optional
6-300mm: included

interchangeable jaws



100-300mm: have two sets
of interchangeable jaws

To be continued

Continued from previous page

- 3-12mm: graduation 0.001mm
12-300mm: graduation 0.005mm
- Ratchet stop
- Optional accessory: setting rings (code **6312**)

Individual

(mm)

Code	Range	Type	Accuracy	Setting ring (included)	Extension rod (included)	L	a	b	c
3227-4 *	3-4mm	A	4µm	Ø4mm	—	22.5	—	—	—
3227-5 *	4-5mm	A	4µm	Ø5mm	—	22.5	—	—	—
3227-6 *	5-6mm	A	4µm	Ø6mm	—	22.5	—	—	—
3227-8 *	6-8mm	B	4µm	Ø6mm	100mm	54.5	1.5	2.5	—
3227-10 *	8-10mm	B	4µm	Ø8mm	100mm	54.5	1.5	2.5	—
3227-12 *	10-12mm	B	4µm	Ø10mm	100mm	54.5	1.5	2.5	—
3227-16 *	12-16mm	C	4µm	Ø16mm	150mm	80	0.5	6	4.5
3227-20 *	16-20mm	C	4µm	Ø16mm	150mm	80	0.5	6	4.5
3227-25 *	20-25mm	C	4µm	Ø25mm	150mm	90	0.5	8	6
3227-30 *	25-30mm	C	4µm	Ø25mm	150mm	90	0.5	8	6
3227-40 *	30-40mm	C	4µm	Ø40mm	150mm	97	0.5	14	12
3227-50 *	40-50mm	C	5µm	Ø40mm	150mm	97	0.5	14	12
3227-63 *	50-63mm	D	5µm	Ø62mm	150mm	114	0.5	17.5	14.5
3227-75 *	62-75mm	D	5µm	Ø62mm	150mm	114	0.5	17.5	14.5
3227-88 *	75-88mm	D	5µm	Ø87mm	150mm	114	0.5	17.5	14.5
3227-100 *	87-100mm	D	5µm	Ø87mm	150mm	114	0.5	17.5	14.5
3227-125 *	100-125mm	D	5µm	—	150mm	145	0.5	19.5	14.5
3227-150 *	125-150mm	D	5µm	—	150mm	145	0.5	19.5	14.5
3227-175 *	150-175mm	D	5µm	—	150mm	145	0.5	19.5	14.5
3227-200 *	175-200mm	D	5µm	—	150mm	145	0.5	19.5	14.5
3227-225	200-225mm	D	7µm	—	150mm	145	0.5	19.5	14.5
3227-250	225-250mm	D	7µm	—	150mm	145	0.5	19.5	14.5
3227-275	250-275mm	D	7µm	—	150mm	145	0.5	19.5	14.5
3227-300	275-300mm	D	7µm	—	150mm	145	0.5	19.5	14.5

Set

Code	Range	Micrometers (included)	Setting ring (included)	Extension rod (included)
3227-363 *	3-6mm	3-4mm, 4-5mm, 5-6mm	Ø4mm, Ø5mm, Ø6mm	—
3227-123 *	6-12mm	6-8mm, 8-10mm, 10-12mm	Ø6mm, Ø8mm, Ø10mm	100mm
3227-202 *	12-20mm	12-16mm, 16-20mm	Ø16mm	150mm
3227-504 *	20-50mm	20-25mm, 25-30mm, 30-40mm, 40-50mm	Ø25mm, Ø40mm	150mm
3227-1004 *	50-100mm	50-63mm, 62-75mm, 75-88mm, 87-100mm	Ø62mm, Ø87mm	150mm

* Supplied with manufacturer inspection certificate